



MINING ENGINEERING
LAB MANUAL

ENGINEERING GRAPHICS & DESIGN
(B.TECH)

SEMESTER I

LIST OF EXPERIMENTS

S.No.	NAME OF EXPERIMENTS	REMARKS
1.	Introduction to Engineering Drawing	
2.	To study Orthographic Projections	
3.	To study Isometric Projections	
4.	To study Projection of Point	
5.	To study Projection of Line	
6.	To study Projection of Plane	
7.	To study Projection of Solids	
8.	To study Projection of Section of Solids	
9.	To study Projection of Development of Surfaces	
10.	To study Projection of Scales	

LAB EXPERIMENT-1

OBJECTIVE

Introduction to Engineering Drawing.

BRIEF DISCUSSION AND EXPLANATION

What is an engineering drawing?

An engineering drawing is a subcategory of technical drawings that show the shape, structure, dimensions, tolerances, accuracy and other requirements needed to manufacture a product or part. Engineering drawings are also known as mechanical drawings, manufacturing blueprints and drawings. An engineering drawing helps to define the requirements of an engineering part and conveys the design concept.

The Engineer distributes these drawings to a manufacturing department to produce the parts, to an assembly department to put the parts together, then to any vendors, archives or other company departments. The drawings can include an item or system's geometry, dimensions, tolerances, functions, finish, hardware and material.

Basic components of engineering drawing

Technical drawings may have different components depending on the industry, the part and the purpose of the drawing.

Types of lines in engineering drawings

An engineering drawing has many different kinds of lines that indicate different concepts and design ideas. Here's a list of the types of lines you can find in an engineering drawing:

Continuous/drawing line

A solid line is the most common type of line and represents an object's physical boundaries. These are the lines used to draw objects. The line thickness can vary—thicker lines are used on the outside contour and thinner lines are used on the inner contour.

Hidden line

Lines that are not visible in the current view are represented by dashes. They represent the edges where surfaces meet but are not directly visible. Hidden lines tend to be omitted from drawings unless they are needed to make the drawing clear.

Center line

Parts with holes and symmetrical features can be shown by using center lines. A center line indicates a circular feature on a drawing and is characterized by its long-short-long alternating line pattern. They can be used to represent:

- 1 Symmetry
- 2 Paths of motion
- 3 Centers of circles and the axes of symmetrical parts

Dimension and extension lines

- 1 Dimension and extension lines are thin lines used to indicate the sizes of features on a drawing.
- 2 Dimension lines show the orientation and extent of a specified length or size of an element. They end with arrowheads that terminate at the extension lines.

3 Extension lines are used to clarify the points at which a dimension begins and ends and extend toward the element that is dimensioned.

Break line

Break lines show where an object is broken to save drawing space or reveal interior features. Break lines come in two forms:

A freehand thick line

A long, ruled thin line with zigzags

Phantom line

Phantom lines are thin long-short-short-long lines used to show the travel or movement of an object or a part in alternate positions. They can also be used to show adjacent objects or features

Section line

Section lines are used to show the cut surfaces of an object in section views. They are fine, dark lines and are generally drawn at a 45° angle. The type of line can indicate various materials such as steel, copper and brass.

Cutting plane line

Cutting plane lines are heavy lines used in section drawings to show the locations of cutting planes. When using a cutout view, the cutting plane lines show the path of the cutout.

Leader line

Leader lines are thin lines used to point to an area of a drawing requiring a note for explanation. They are usually drawn at 45-degree angles.

Types of views in engineering drawings

Engineering drawings often utilize different types of views to contribute to the understanding of a design. Here are various types of views used in engineering drawings.

Isometric view

Isometric drawings show parts as three-dimensional. Vertical lines stay vertical (compared to the front view) and parallel lines are shown at an angle, usually 30 degrees. In an isometric drawing, the object appears as if it is being viewed from above from one corner

The lines that are vertical and parallel are in their true length. This means you can use a ruler and the scaling of the drawing to measure the length.

Orthographic view

An orthographic view represents a 3-D object using several two-dimensional views of the object. Standard practice calls for three orthographic views, a front, top and side view. This kind of representation allows for avoiding any kind of distortion of lengths.

Different areas of the world use different angle projections to show orthographic views. You can tell which angle projection is used by the symbol shown on the drawing.

First-angle projection: The International Organization for Standardization (ISO) calls for this kind of

projection.

Third-angle projection: The American National Standards Institute (ANSI) calls for this kind of projection and is the accepted method in the United States.

Section view

A section view looks provides a view of inside an object. Sections are used to clarify the interior construction of a part that cannot be clearly described by hidden lines in exterior views. The cut material is indicated with diagonal section lines.

Cutout view:

This view is similar to the section view. While the section view shows the cutting of the entire model, and the cut-out view would be cutting only a smaller portion of the model. This view helps to reduce the number of orthographic views in the drawing.

Detail view

Detailed views are scaled-up versions of orthographic views, which are essential in complex models with small intricacies. They zoom into a selected section of a larger view.

Auxiliary view

An auxiliary view is an orthographic view for nonhorizontal or nonvertical planes. It helps to present inclined surfaces without distortion.

Dimensions

The text of dimensions can be placed inside or outside the extension lines or drawn at an angle if space is limited. All dimensions and note text should be oriented to read from the bottom of the drawing. This is called unidirectional dimensioning.

Information blocks

These are little boxes present at the bottom corner of the engineering drawing. The block includes part name and number, author's name, coating, quantity, scale and other information.

Title block: This is usually at the bottom right of the drawing and includes identifying information like the title, number, part numbers, measurements, intellectual property notes and information about the agency that made the drawing.

Revisions block: The revisions block is usually at the top right or with the title block and lists other versions of the drawing.

Bill of materials block: This block is a list of material requirements for a given project. If a drawing requires too many items to fit in a block, then the list of materials will be provided on separate sheet.

- **DESIGNATION OF SHEETS:**

Designation	Trimmed	Untrimmed Size
A1	594 x 841	625 x 880

A2	420 x 594	450 x 625
A3	297 x 420	330 x 450
A4	210 x 297	240 x 330

QUIZ WITH ANSWERS

Q1 – Define engineering drawing. Why drawing is called universal language of engineers?

Ans: A drawing drawn by an engineer having engineering knowledge for the drawing purposes is an engineering drawing. It is meant for communicating his ideas, thoughts and designs to others. Engineering drawing is a starting point of all engineering branches such as Mechanical, Production, Civil, Electrical, Electronics, Computer science, Chemical etc. It is spoken, read, and written in its own way. Engineering drawing has its own grammar in the theory of projections, its idioms in conventional practices, its punctuations in the types of lines, its abbreviations, symbols and its descriptions in the constructions.

Q2 – Name different types of drawing instruments.

Ans: Drawing board, T-square, Set Square, Scales, Pencil and sand paper block, Drawing pins or cello-tape, Duster or handkerchief, eraser etc.

Q3 – Why pencil is rotated in finger while drawing a long line?

Ans: The pencil is rotated in finger while drawing a long line in order to get a line of uniform thickness throughout.

Q4 – Why cello-tape is used instead of drawing pins, now a day?

Ans: Now a days, cello tapes are used in place of drawing pins for its practical convenience as the drafter, T-square and set-squares can be moved easily over the tape.

Q5 – What is layout of drawing sheet?

Ans: The selection of suitable scale and allotment of proper space for margin, title block, parts list, revision panel, folding marks etc. on the drawing sheet is known as layout of drawing sheet

Q6 – Why is the layout of sheet is necessary?

Ans: Layout of the drawing on the drawing sheet is necessary in order to make its reading easy and speedy. The title blocks, parts list etc will provide all the required information.

Q7 – List out the contents of title block and material list

Ans: The title block should contain at least the following information

- (i) Name of the institution
- (ii) Name of title of drawing
- (iii) Name, Class and Roll no. of the student
- (iv) Scale
- (v) Drawing number
- (vi) Symbols denoting the method of projection

LAB EXPERIMENT-2

OBJECTIVE

To study Orthographic Projections

BRIEF DISCUSSION AND EXPLANATION

Orthographic Projection is a method of producing dimensioned working drawings or blueprints of 3-D Objects using a series of related 2-D views of the object to communicate the object's length, width and depth.

The views are produced by using the fundamental concept of Orthographic Projection - the location of the Spectator (the viewer). The Spectator is always located at an infinite distance from the object and planes of reference - this means that the lines of sight (projection lines) remain parallel and will project on to a Plane which is perpendicular to the projection lines.

The primary views used are called the Elevation, Plan and End Elevation and are produced by projecting an image of the object as viewed by a spectator standing at infinity on to the Planes of Reference which are then folded flat to produce a 2-D drawing. Drawings can be used using one of two methods - First Angle Projection (Used in Europe, Asia & Africa) or Third Angle Projection (Used in the USA). First Angle Projection involves the projection of the image of the object on to a Plane positioned behind the object while Third Angle projects the image on to a plane located between the object and the spectator. The method of projection alters the layout of the drawing as displayed in the image below. Drawings created using First Angle Projection will have the Plan View located below the elevation and End Elevation positioned on the side opposite the viewing direction (i.e. when viewing the left of the object the view is positioned on the right of the Elevation) while the opposite is the case for Third Angle Projection.

.

Conventions of Orthographic Projection

There are a number of rules and conventions which must be adhered to when producing Orthographic Drawings:

- Heights of objects will remain the same between Elevations including End Elevations and Auxiliary Elevations.
- Widths of Objects will remain the same between the main Elevation, Plan and Auxiliary Plans.
- Lines & Surfaces parallel to the Vertical Plane will appear as true lengths/shapes in the Elevation.
- Lines & Surfaces parallel to the Horizontal Plane will appear as true lengths/shapes in the Plan.
- 45° Lines or Arcs should be used to transfer widths between the plan and End Elevation.
- Construction lines should be drawn lightly using a H Pencil.
- Finished lines should be drawn heavily using a B Pencil.



Fig: Orthographic Projections

QUIZ WITH ANSWERS

Q1. An orthographic projection map is a map projection of _____

Ans: Like the stereographic projection and gnomonic projection, orthographic projection is a perspective (or azimuthal) projection, in which the sphere is projected onto a tangent plane or secant plane. The point of perspective for the orthographic projection is at infinite distance. It depicts a hemisphere of the globe as it appears from outer space, where the horizon is a great circle. The shapes and areas are distorted, particularly near the edges.

Q2. Taking 'A' as the FRONT VIEW. Which view will letter 'D' represent in the following figure?

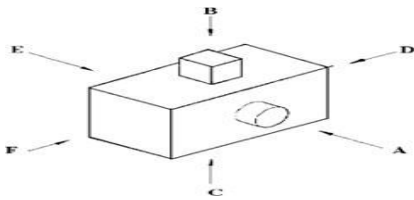

Ans: This represents the side view of an object.

Q3. Which view will letter 'C' represent in the above following figure?

Ans: This is the bottom view representation of the any object. C represents the bottom view. The dotted small rectangle represents that the particular object is on the other side of the viewing plane.

Q4. Which view will letter 'E' represent in the above following figure?

Ans: This is the back view representation of the any object. E represents the back view. The dotted circle represents that the particular object is on the other side of the viewing plane.

Q5. Define orthographic projection

Ans: Orthographic Projection is a method of producing dimensioned working drawings or blueprints of 3-D Objects using a series of related 2-D views of the object to communicate the object's length, width and depth.

LAB EXPERIMENT-3

OBJECTIVE

To study Isometric Projections

BRIEF DISCUSSION AND EXPLANATION

Isometric drawing, sometimes called isometric projection, is a type of 2D drawing used to draw 3D objects that is set out using 30-degree angles. It's also a type of axonometric drawing, meaning that the same scale is used for every axis, resulting in a non-distorted image. Since isometric grids are pretty easy to set up, once you understand the basics of isometric drawing, creating a freehand isometric sketch is relatively simple.

An isometric drawing is a 3D representation of an object, room, building or design on a 2D surface. One of the defining characteristics of an isometric drawing, compared to other types of 3D representation, is that the final image is not distorted and is always to scale. This is due to the fact that the foreshortening of the axes is equal. The word isometric comes from Greek to mean 'equal measure'.

Isometric drawings are a good way to show measurements and how components fit together, and is used in technical drawing, often by engineers and architects. They differ from other types of axonometric drawing, including dimetric and trimetric projections, in which different scales are used for different axes to give a distorted final image.

In an isometric drawing, the object appears as if it is being viewed from above from one corner, with the axes set out from this corner point. Isometric drawings begin with one vertical line along which two points are defined. Any lines set out from these points should be constructed at an angle of 30 degrees.

ISOMETRIC DRAWING VS ONE-POINT PERSPECTIVE

Both isometric drawings and one-point perspective drawings use geometry and mathematics to present 3D representations on 2D surfaces. One-point perspective drawings mimic the human eye, so objects appear smaller the further away they are from the viewer. In contrast, isometric drawings use parallel projection, which means objects remain at the same size, no matter how far away they are.

Basically, isometric drawing doesn't use perspective in its rendering (i.e. lines don't converge as they move away from the viewer). Isometric drawings are more useful for functional drawings that are used to explain how something works, while one-point perspective drawings are typically used to give a more sensory idea of an object or space.

The limitation of isometric drawings compared to 3D models is that you can't change your vantage point, you have to see the drawing from the top viewpoint.

THE BENEFITS OF ISOMETRIC DRAWING

Isometric drawings are very useful for designers – particularly architects, industrial and interior designers and engineers, as they are ideal for visualising rooms, products, and infrastructure. They're a great way to quickly test out different design ideas. They also illustrate the 3D nature of an object, without being drawn in 3D software, and measurements can be made to scale along the principal axes.

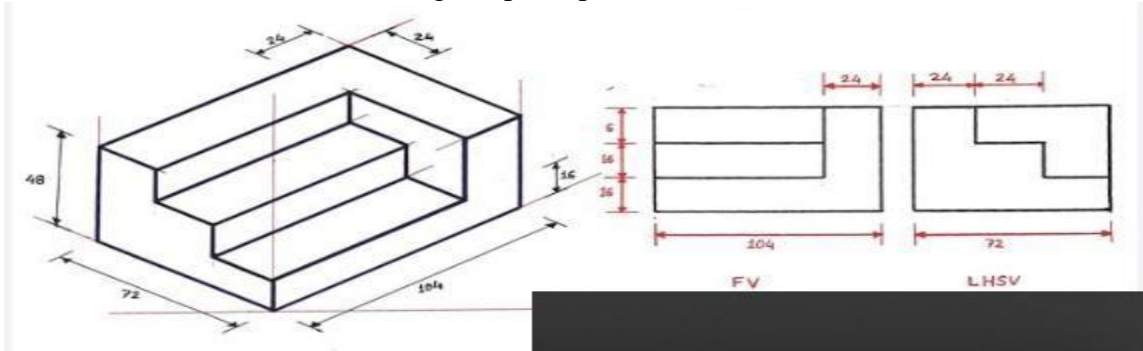

Fig: Isometric Projections

QUIZ WITH ANSWERS

Q1. Isometric drawings are often used by _ to help illustrate complex designs.

Ans: Mechanical engineers, Piping drafters & Aerospace engineers

Q2. What is isometric view?

Ans: The view drawn to the exact scale is known as the Isometric View (Isometric Drawing). While that drawn using the isometric scale is known as as the Isometric Projection. In the figure, the three perpendicular edges of the cube OX, OY, & OZ are foreshortened equally and are at equal inclinations of 120° to each other and are known as isometric axes.

Q3. What is the axonometric angle of the isometric projection?

Ans: Since the three perpendicular edges of an object are projected in the isometric projection at equal axonometric angles, the angles between those edges in the isometric projection will be at 120° . The lengths of the three perpendicular edges of an object in the isometric projection are foreshortened in the same proportion.

Q4. Is XYZ an oblique surface in isometric projection?

Ans: The surface XYZ is an oblique surface in isometric. An object in isometric projection may be shown in eight different positions as shown in the Figure. Anyone particular position may be selected so as to illustrate all the important details of the object clearly.

Q5. If isometric projection of an object is drawn with true lengths the shape would be same and size is how much larger than actual isometric projection?

Ans: If the foreshortening of the isometric lines in an isometric projection is disregarded and instead, the true lengths are marked, the view obtained will be exactly of the same shape but larger in proportion than that obtained by the use of the isometric scale.

Q6. If an isometric projection is drawn with true measurements but not with isometric scale then the drawings are called?

Ans: Due to the ease of construction and the advantage of measuring the dimensions directly from the drawing, it has become a general practice to use the true scale instead of the isometric scale.

Q7. If an isometric drawing is made use of isometric scale then the drawings are called?

Ans: To avoid confusion, the view drawn with the true scale is called isometric drawing or isometric view, while that drawn with the use of isometric scale is called isometric projection.

LAB EXPERIMENT-4

OBJECTIVE

To study Projection of Point

BRIEF DISCUSSION AND EXPLANATION

Projection of Points

1. A point represents a location in space or on a drawing, and has no width, height and depth.
2. A point is represented by the intersection of two lines.

Positions of a point

1. When a point lies in the first quadrant, it will be above H.P. and in front of V.P.
2. When the point lies in the second quadrant, it will be above H.P. and behind V.P.
3. When the point lies in the third quadrant, it will be below H.P. and behind V.P.
4. When the point lies in the fourth quadrant, it will be in front of V.P. and below H.P.

System of notation

1. In this text, the actual points in space are denoted by capital letters A, B, C etc.
2. Their front views are denoted by their corresponding lower case letters with dashes a', b', c' etc., and their top views by the lower case letters a, b, c etc.
3. Projectors are always drawn as continuous thin lines (2H pencil).

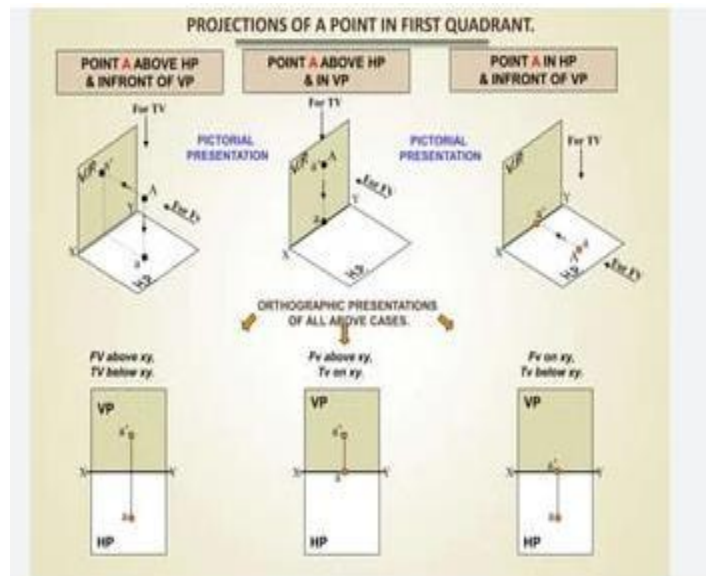

Fig: Projection of Point

QUIZ WITH ANSWERS

Q1. Two points are placed in 1st quadrant of projection planes such that the line joining the points is to profile plane the side view and top view will be single point and two points.

Ans: Here the two points such that the joining line is perpendicular to profile plane in 1st quadrant and given side view and top view. The views in any quadrant will remain the same but the relative positions in projection will change accordingly the quadrant.

Q2. A point is 6 units away from the vertical plane and 3 units away from the profile plane and 7 units away from the horizontal plane in 1st quadrant then the projections are drawn on paper. The distance between the top view and front view of point is?

Ans: Since the point is 6 units away from the vertical plane the distance from the point to the reference line will be 6 units. And then the point is at a distance of 7 units from the horizontal plane the distance from the reference line and point will be 7, the sum is 13.

Q3. If a point P is placed in between the projection planes. The distance from side view to reference line towards the front view and the distance between the top view and reference line towards the top view will be different.

Ans: The projection will be drawn by turning the other planes parallel to a vertical plane in a clockwise direction along the lines of intersecting of planes. And so as we fold again the planes at respective reference lines and then drawing perpendiculars to the planes at those points the point of intersection gives the point P.

Q4. When a point is in a _____, its projection on the other reference plane is in xy

Ans: When a point is in front of the V.P, its top view is below xy; when it is behind the V.P, the top view is above xy. The distance of a point from the V.P is shown by the length of the projector from its top view to xy.

Q5. The line joining the front and top views of a point are called?

Ans: The front view a' is above xy and the top view a below it. The line joining a' and a(which also is called a projector), intersects xy at a right angle at a point o. The projector connecting the front and top views of a point is always perpendicular to the xy.

Q6. The front view of a point is 40mm above xy and the top view is 50mm below xy. The point is?

Ans: Given that front view of a point is 40mm above xy and the top view is 50mm below xy, so the point will be 40mm above H.P and 50mm from V.P.

LAB EXPERIMENT-5

OBJECTIVE

To study Projection of Lines

BRIEF DISCUSSION AND EXPLANATION

- 1 A straight line is the shortest route to join any two given points.
- 2 It is a one-dimensional object having only length (l).
- 3 The projection of straight line are obtained by joining the top and front views of the respective end points of the line.
- 4 The actual length of the straight line is known as true length (TL).

Different positions of a line wrt principle planes

- Parallel to both the planes (HP and VP)
- Parallel to one plane and perpendicular to the other
- Parallel to one plane and inclined to the other
- Inclined to both the planes

TRACE OF A LINE

- 1 The point of intersection or meeting of a line with the reference plane, extended if necessary, is known as the trace of a line.
- 2 The point of intersection of a line with the HP is known as the horizontal trace, represented by HT and that with the VP is known as the vertical trace, represented by VT.
- 3 No trace is obtained when a line is kept parallel to a reference plane.
- 4 If the line is given parallel to a plane, it will never intersect that plane and, therefore, no trace of the line on that plane. If the line is given parallel to VP and inclined to HP, only HT will be obtained and no VT.
- 5 If the line is given parallel to HP and inclined to VP, only VT will be obtained and no HT.
- 6 If the line is given parallel to both the planes, neither HT nor VT will be obtained.

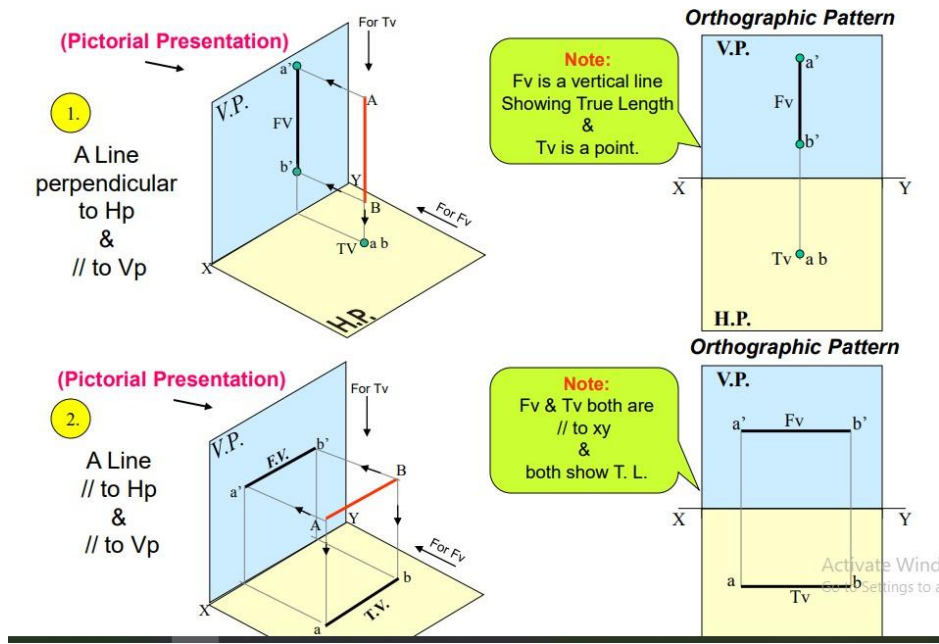

Fig: Projection of lines

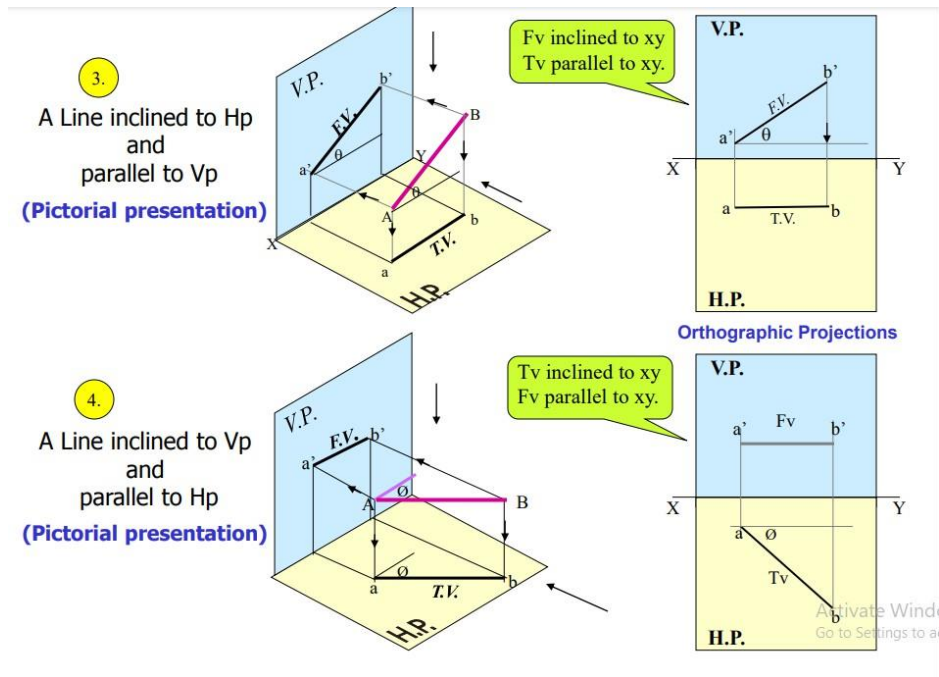

Fig: Projection of lines

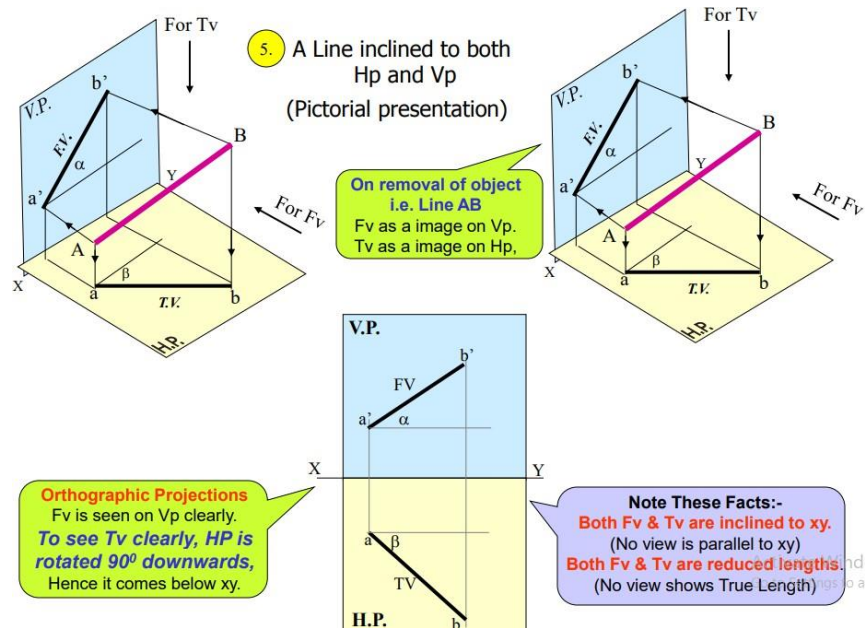

Fig: Projection of lines

QUIZ WITH ANSWERS

Q1. What is the orthogonal projection of a line to a plane?

Ans: The orthogonal projection of a line to a plane will be a line or a point. If a line is perpendicular to a plane, its projection is a point. Give the formula for the perpendicular distance of a point (x_1, y_1) to the line $ax+by+c=0$. The perpendicular distance of a point (x_1, y_1) to the line $ax+by+c=0$ is given by

Q2. How to find projection of a line on a plane?

Ans: In this article, we will learn how to find Projection of line on plane with an example.

Consider line AB and a point P. Construct a perpendicular PQ from P on AB that meets AB at Q. This point Q is known as the projection of P on the line AB. What is the Projection of a Line on a Plane?

Q3. How do you projection a line that is not parallel or perpendicular?

Ans: Projection of a line which is not parallel nor perpendicular to a plane will pass through their intersection B and through the projection A' of any point A of the line onto the plane, as shown in the figure above. Find the equations of the projection of the line $(x+1)/-2 = (y-1)/3 = (z+2)/4$ on the plane $2x+y+4z = 1$.

Q4. A line AB is on the vertical plane of projection planes, which view from the following gives the actual length of the line AB?

Ans: Any line that lie or parallel to any of plane in projection planes the true length will be found at view which drawn on to that plane that is here the line is in vertical plane so the view which fall on vertical plane gives the true length which is other than front view.

Q5. A line AB is on the profile plane inclined such that ends of line are 10, 12 cm away from horizontal plane, which view from the following gives the actual length of the line AB?

Ans: Any line that lie or parallel to any of plane in projection planes the true length will be found at view which

drawn on to that plane that is here the line is in profile plane though it's ends are at some distance the true length will be given at view which fall on profile plane which is side view.

Q6. A line PQ lie in both the vertical plane and profile plane the front and side views of that line coincides at vertical reference line

Ans: Given a line present in both the planes but it is known that two perpendicular planes meet at a line which is reference line so the given line might present on that line that coincides with that line so the views also get coincide at that line.

LAB EXPERIMENT-6

OBJECTIVE

To study Projection of Planes

BRIEF DISCUSSION AND EXPLANATION

1. A plane is a 2- dimensional object having length and breadth only
2. Its thickness is always neglected
3. Various shapes of plane figures are considered such as square, rectangle, circle, pentagon, hexagon, etc.

Meaning of Trace of a Plane

- 1 It is defined as the extension of a given plane shape to the reference plane (HP or VP) to which it is perpendicular or inclined.
- 2 The plane meets the HP or VP as a line. This line is called trace of a plane.

Horizontal Trace(HT) & Vertical Trace (VT) a plane.

- 1 The line in which the plane shape meets the HP is called HT.
- 2 The line in which the plane shape meets the VP is called as VT.

The following position of Planes in space

- Planes Parallel to VP and Perpendicular to HP
- Planes Perpendicular to VP and Parallel to HP
- Planes Parallel to both VP and HP or both Perpendicular VP and HP
- Planes Perpendicular to VP and Inclined to HP
- Planes Inclined to VP and Perpendicular to HP
- Planes Inclined to both VP and HP

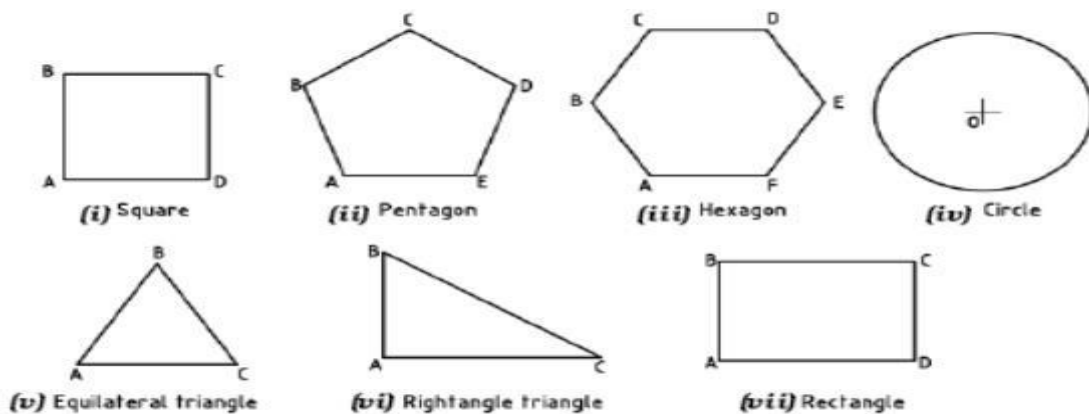
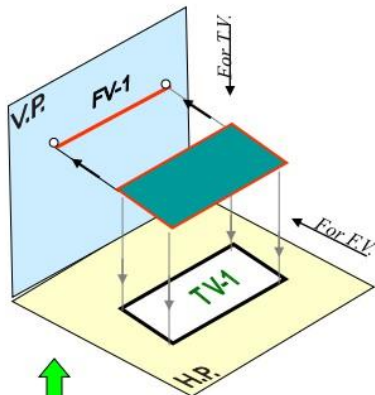
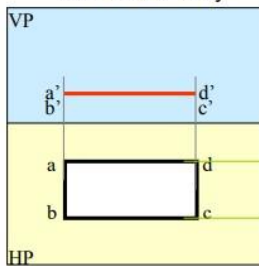

Fig: Projection of Planes

SURFACE **PARALLEL TO HP**
PICTORIAL PRESENTATION



ORTHOGRAPHIC
TV- True Shape
FV- Line // to xy



SURFACE **INCLINED TO HP**
PICTORIAL PRESENTATION

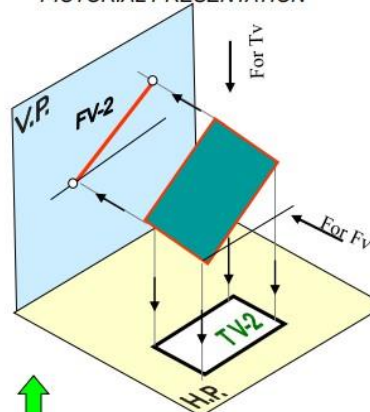

ORTHOGRAPHIC
FV- Inclined to XY
TV- Reduced Shape

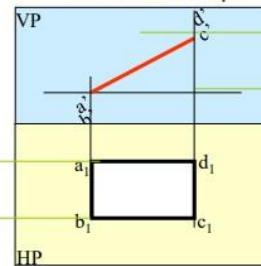

ONE SMALL SIDE INCLINED TO VP
PICTORIAL PRESENTATION

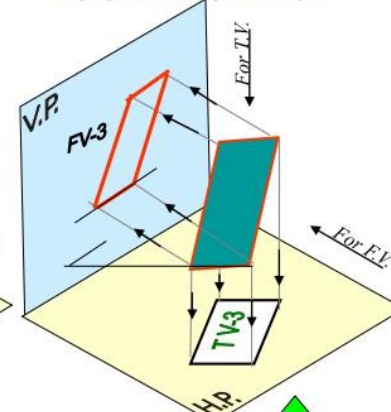

ORTHOGRAPHIC
FV- Apparent Shape
TV- Previous Shape

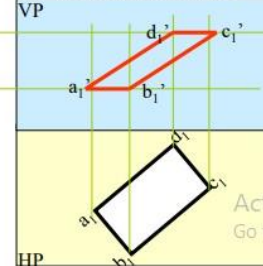

Fig: Projection of Planes

QUIZ WITH ANSWERS

Q1. What is the difference between projection and auxiliary plane?

Ans. Projection is an image or a view. Projectors are the lines drawn from each and every point of the object. These lines are perpendicular to the plane of projection & parallel to each other. Plane of projection (POP) is the plane on which image is drawn

Q2. What is a plane of projection (pop)?

Ans: Plane of projection (POP) is the plane on which image is drawn

Q3. What is the difference between a projection and a projector?

Ans: projection is an image or a view. Projectors are the lines drawn from each and every point of the object. These lines are perpendicular to the plane of projection & parallel to each other. Plane of projection (POP) is the plane on which image is drawn

Q4. What is the projection of a plane?

Ans: The projection of a plane is the image formed when the plane is intersected by a projection surface, such as a screen or a plane.

Q5. How many types of projections of planes are there?

Ans: There are three types of projections of planes: parallel projection, perspective projection, and oblique projection.

Q6. What is a parallel projection of a plane?

Ans: A parallel projection of a plane is formed when the projection rays are parallel to each other. It results in a 2D image that preserves the shape and size of the plane.

Q7. What is a perspective projection of a plane?

Ans: A perspective projection of a plane is formed when the projection rays converge at a single point, known as the projection center. It creates a 2D image that simulates the way our eyes perceive depth and distance.

Q8. What is an oblique projection of a plane?

Ans: An oblique projection of a plane is formed when the projection rays are neither parallel nor convergent. It results in a 2D image where the plane is projected at an angle.

Q9. What are some applications of plane projections?

Ans: Plane projections are commonly used in architectural and engineering drawings, computer graphics, animation, and visualization to represent 3D objects and scenes in a 2D space.

Q10. Can a plane be projected onto another plane?

Ans: Yes, a plane can be projected onto another plane using various projection techniques. The resulting image will depend on the type of projection used and the relative orientation of the planes.

LAB EXPERIMENT-7

OBJECTIVE

To Study Projection of Solids

BRIEF DISCUSSION AND EXPLANATION

1. A solid has three dimensions, viz. length, breadth and thickness.
2. To represent a solid on a flat surface having only length and breadth, at least two orthographic views are necessary

Types of Solids

Solids may be divided into two main groups:

- i. Polyhedron
- ii. Solids of revolution.

There are six regular polyhedron

- **Tetrahedron** : It has four equal faces, each an equilateral triangle.
- b. **Cube or Hexahedron** : It has six faces, all equal squares.
- c. **Octahedron** : It has eight equal equilateral triangles as faces.
- d. **Dodecahedron** : It has twelve equal and regular pentagons as faces.

Prism:

This is a polyhedron having two equal and similar faces called its ends or bases, parallel to each other and joined by other faces, which are parallelograms. The imaginary line joining the centers of the bases is called the axis. A right and regular prism has its axis perpendicular to the bases. All its faces are equal rectangles.

Pyramid:

This is a polyhedron having a plane figure as a base and a number of triangular faces meeting at a point called the vertex or apex. The imaginary line joining the apex with the centre of the base is its axis. A right and regular pyramid has its axis perpendicular to the base, which is a regular plane figure. Its faces are all equal isosceles triangles.

Frustum:

When a pyramid or a cone is cut by a plane parallel to its base, thus removing the top portion, the remaining portion is called its frustum.

Truncated:

When a solid is cut by a plane inclined to base it is said to be truncated.

The following position of Solids in space

- Planes Parallel to VP and Perpendicular to HP
- Planes Perpendicular to VP and Parallel to HP
- Planes Parallel to both VP and HP or both Perpendicular VP and HP
- Planes Perpendicular to VP and Inclined to HP
- Planes Inclined to VP and Perpendicular to HP
- Planes Inclined to both VP and HP

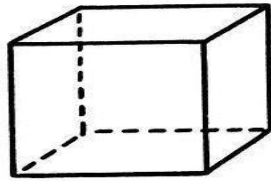

Cube

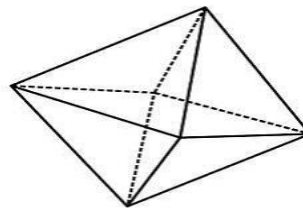

Octahedron

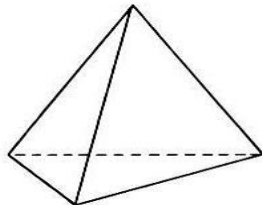

Tetrahedron

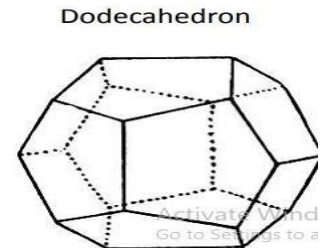

Dodecahedron

Fig: Tetrahedron

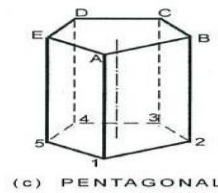
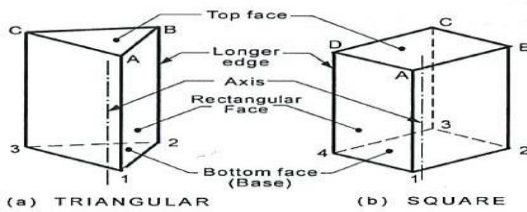

(c) PENTAGONAL

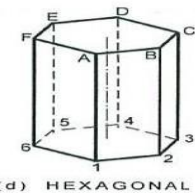

(d) HEXAGONAL

Fig: Prism

Activate Word
Go to Settings to a

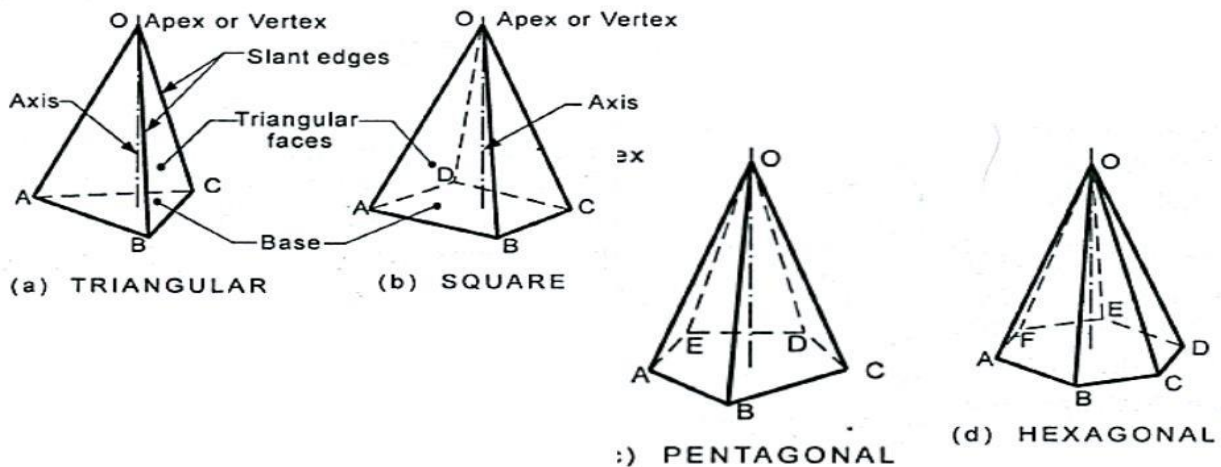

Fig: Pyramid

Activate Wind

QUIZ WITH ANSWERS

Q1. What is the projection of a solid?

Ans: The projection of a solid is the representation of its 3D form onto a 2D surface.

Q2. How many types of projections of solids are there?

Ans: There are two commonly used types of projections for solids: orthographic projection and perspective projection.

Q3. What is an orthographic projection of a solid?

Ans: An orthographic projection of a solid is formed by projecting its points onto a plane parallel to the object. It results in a 2D representation that shows the object's true shape and size.

Q4. What is a perspective projection of a solid?

Ans: A perspective projection of a solid is formed by projecting its points onto a plane from a specific viewpoint. It creates a 2D representation that simulates how the object appears in three dimensions, considering foreshortening and perspective effects.

Q5. How are projections of solids typically represented?

Ans: Projections of solids are often represented using orthographic projection drawings, which include multiple views (such as front, top, and side views) to depict the object from different angles.

Q6. What are some applications of solid projections?

Ans: Solid projections are extensively used in engineering, architecture, industrial design, and manufacturing. They help in visualizing and communicating the design, dimensions, and details of 3D objects.

LAB EXPERIMENT-8

OBJECTIVE

Projection of Section of Solids

BRIEF DISCUSSION AND EXPLANATION

Theory of Sectioning

- Whenever a section plane cuts a solid, it intersects (and or coincides with) the edges of the solids.
- The point at which the section plane intersects an edge of the solid is called the *point of intersection* (POI).
- In case of the solids having a curved surface, viz., cylinder, cone and sphere, POIs are located between the cutting plane and the lateral lines.

Sectional Views

- The internal hidden details of the object are shown in orthographic views by dashed lines.
- The intensity of dashed lines in orthographic views depends on the complexity of internal structure of the object.
- If there are many hidden lines, it is difficult to visualize the shape of the object
 - unnecessarily complicated and confusing.
- Therefore, the general practice is to draw sectional views for complex objects in addition to or instead of simple orthographic views.

A sectional view, as the name suggests, is obtained by taking the section of the object along a particular plane. An imaginary cutting plane is used to obtain the section of the object

True Shape of Sections

- A section will show its *true shape* when viewed in normal direction.
- To find the true shape of a section, it must be projected on a plane parallel to the section plane.
- For polyhedra, the true shape of the section depends on the number of POIs. The shape of the section will be a polygon of the sides equal to the number of POIs.
- The true shape of the section of a sphere is always a circle.
- The sections of prisms and pyramids are straight line segmented curves.
- The sections of cylinders and cones will mostly have smooth curves.

Types of Cutting Planes and Their Representation

- A cutting plane is represented by a cutting plane line
- The cutting plane line indicates the line view of the cutting plane.
- The two ends of the cutting plane line are made slightly thicker and provided with arrows.
- The direction of the arrow indicates the direction of viewing of the object.
- In the first-angle method of projection, the direction of the arrows is toward the POP, i.e., toward *XY* (or *X1Y1*).

Types of section planes

- Vertical Section plane
- Horizontal Section Plane
- Profile Section plane
- Auxiliary Section plane
- Oblique Section plane

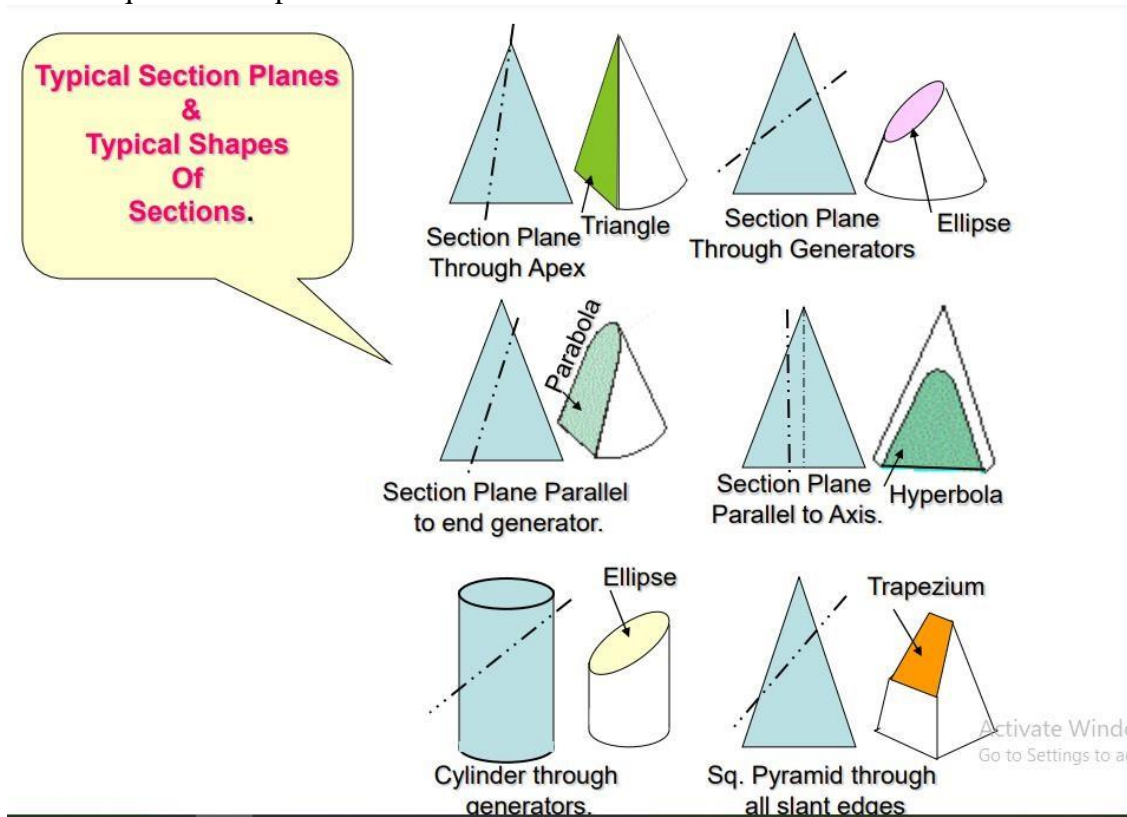

Fig: Projection of Section of Solids

QUIZ WITH ANSWERS

Q1. What is the sectioning of a solid?

Ans: Sectioning of a solid is the process of cutting or slicing through a solid object to reveal its internal structure.

Q2. What is the purpose of sectioning a solid?

Ans: Sectioning is done to provide a clearer understanding of the internal features, dimensions, and relationships within a solid object.

Q3. How is sectioning of solids represented?

Ans: Sectioning of solids is typically represented using section views in technical drawings. These views show the shape, size, and arrangement of internal features after cutting through the object.

Q4. What are some commonly used types of section views?

Ans: Some commonly used types of section views include full sections, half sections, offset sections, revolved sections, and broken-out sections.

Q5. How are section views indicated in technical drawings?

Ans: Section views are indicated by cross-hatching or shading within the cut portion of the solid object. This helps distinguish the solid material from the void or hollow space.

Q6. What is the purpose of cross-hatching in section views?

Ans: Cross-hatching in section views is used to differentiate between the solid material and the void created by the cut. It provides visual clarity and enhances the understanding of the internal structure.

Q7. Can multiple section views be used for a single solid object?

Ans: Yes, multiple section views can be used for a single solid object to reveal different aspects of its internal structure. Each section view provides a unique perspective and reveals specific details.

Q8. What are some applications of sectioning in engineering and design?

Ans: Sectioning is widely used in engineering and design fields, such as architecture, mechanical engineering, and manufacturing. It helps in visualizing and communicating internal features, assembly details, and material properties of solid objects.

LAB EXPERIMENT - 9

OBJECTIVE

Projection of Development of Surfaces

- A development is the unfold/unrolled flat / plane figure of a 3-D object.
- Called also a pattern, the plane may show the true size of each area of the object.
- When the pattern is cut, it can be rolled or folded back into the original object.

BRIEF DISCUSSION AND EXPLANATION

Methods of development of surfaces are:

1. Parallel line development
2. Radial line development
3. Triangulation development
4. Approximate development

Parallel line development uses parallel lines to construct the expanded pattern of each three-dimensional shape. The method divides the surface into a series of parallel lines to determine the shape of a pattern. Example: Prism, Cylinder.

Radial line development uses lines radiating from a central point to construct the expanded pattern of each three-dimensional shape. Example: Cone, Pyramid.

Triangulation developments are made from polyhedrons, singlecurved surfaces, and wrapped surfaces. Example: Tetrahedron and other polyhedrons.

In approximate development, the shape obtained is only approximate. After joining, the part is stretched or distorted to obtain the final shape. Example: Sphere.

A true development is one in which no stretching or distortion of the surfaces occurs and every surface of the development is the same size and shape as the corresponding surface on the 3-D object. e.g. polyhedrons and single curved surfaces

An approximate development is one in which stretching or distortion occurs in the process of creating the development.

The resulting flat surfaces are not the same size and shape as the corresponding surfaces on the 3-D object. Wrapped surfaces do not produce true developments, because pairs of consecutive straight-line elements do not form a plane.

Also double-curved surfaces, such as a sphere do not produce true developments, because they do not contain any straight lines.

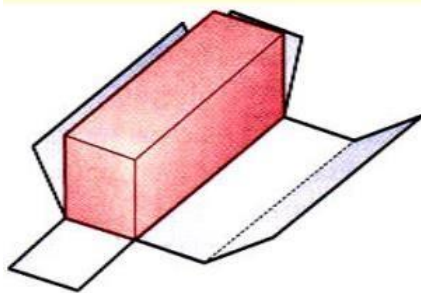

(A) Prism
(Parallel line development)

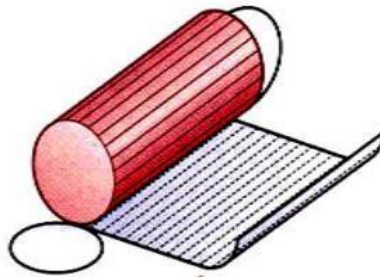

(B) Cylinder
(Parallel line development)

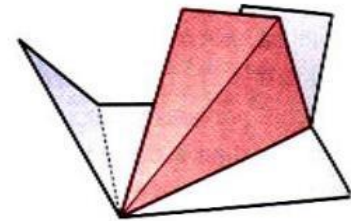

(C) Pyramid
(Radial line development)

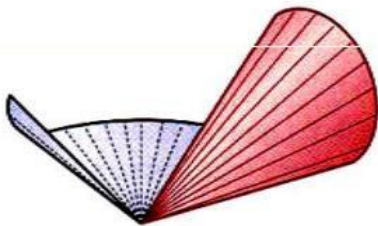

(D) Cone
(Radial line development)

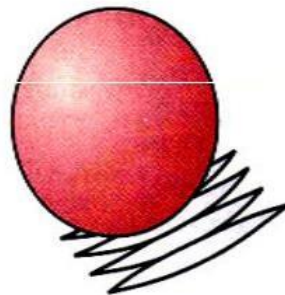

(E) Sphere
(Approximate development)

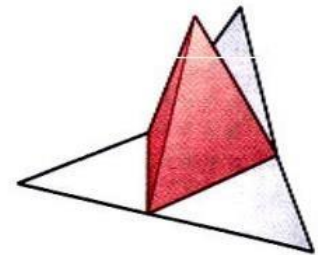

(F) Tetrahedron
(Triangulation development)

Fig: Projection of Development of Surfaces

QUIZ WITH ANSWERS

Q1. What is the projection development of surfaces?

Ans: The projection development of surfaces is a technique used to unfold or flatten a curved surface onto a 2D plane while preserving its shape and dimensions.

Q2. What is the purpose of projection development of surfaces?

Ans: The purpose of projection development is to create a 2D pattern or template that can be used to fabricate or construct the original curved surface.

Q3. How is projection development of surfaces represented?

Ans: Projection development of surfaces is typically represented using unfoldings or developable patterns, which show how the curved surface can be flattened onto a flat plane.

Q4. What types of surfaces can be subjected to projection development?

Ans: Developable surfaces, which include surfaces like cylinders, cones, and developable ruled surfaces, are the primary candidates for projection development.

Q5. How is projection development useful in manufacturing and design?

Ans: Projection development is useful in manufacturing and design as it allows for the creation of flat patterns that can be used to cut, shape, or fold materials into the desired curved shape.

Q6. What are some common techniques for projection development?

Ans: Some common techniques for projection development include triangulation, radial line development,

parallel line development, and radial line expansion.

Q7. Can any curved surface be perfectly flattened through projection development?

Ans: No, not all curved surfaces can be perfectly flattened without distortion. Only developable surfaces can be unfolded or developed onto a 2D plane without introducing stretching or bending.

Q8. What are some limitations or challenges in projection development?

Ans: Projection development may encounter challenges when dealing with complex curved surfaces that are non-developable or have irregular geometries. In such cases, approximations or additional techniques may be required.

LAB EXPERIMENT - 10

OBJECTIVE

Projection of Scales

BRIEF DISCUSSION AND EXPLANATION

In this detailed guide on different **types of scales in engineering drawing**, we will discuss **engineering drawing scales** and their designation for use on all technical drawings in any field of engineering.

What is a scale in engineering drawings?

The scales are the ratio of the linear **dimension** of an element of an object as represented in the original drawing to the actual linear dimension of the same element of the object itself. The scales in engineering drawing are a set of levels or numbers which are used in a particular system as a measuring or comparing parameter.

The engineering scales are made in a variety of graduation to meet the requirements of many different kinds of engineering works. The engineering scale adopted for drawing should have a bearing on the degree of accuracy required of scaled measurements on prepared drawings.

Full scale, Enlarging scale, and Reducing scales in Engineering drawing -

It is not always possible to draw an object to its actual size. For example, drawings of very large objects cannot be plotted in full size because they are too large to adjust on the drawing sheet. Again, drawing a very small object cannot be drawing in full size because it would be too small to draw and to read.

There are different types of scales in engineering drawing are used so that objects can be accommodated and comfortably be plotted and read are as follows:

Full scale: when an engineering drawing is prepared to the actual size of the object, the scale used is termed as full-size scale and the drawing is known as full-size drawing.

A scale with a ratio of 1:1 is known as a full-size scale *in engineering drawing*.

Example: A 30 mm radius plain disc is represented on the drawing by a circle of 30 mm radius.

Enlarging scale: When a very small object such as components of a wristwatch, is enlarged in some regular proportion to accommodate its drawing. So when the drawing is prepared larger than the actual size, the scale is said to be an enlarged scale, and the drawing is said to be an enlarged-sized drawing.

A scale in which the ratio is larger than 1:1.

Reducing scale: When the object is of large size, the actual dimensions of the object have to be reduced to accommodate the drawn object in the drawing sheet. So when a drawing is prepared smaller than the actual size of the object, the scale used is termed as reducing scale and the drawing is known as a reduced-sized drawing.

A scale in which the ratio is smaller than 1:1.

Representative Fraction (RF)

The representative fraction is defined as the ratio of the dimension of an element of an object in the drawing to its actual linear dimension of the same element of the object itself.

Types of scale in engineering drawing

The scales in engineering drawing are classified as the following:

1. Plain scale
2. Diagonal scale
3. Vernier scale
4. Comparative scale
5. Scale off chords